

16-INCH WIDE UNDERCOUNTER FILTER MAGIC CASTER AND LEG INSTALLATION INSTRUCTIONS

SEE 819-5369 FOR LOCATING INSTRUCTIONS

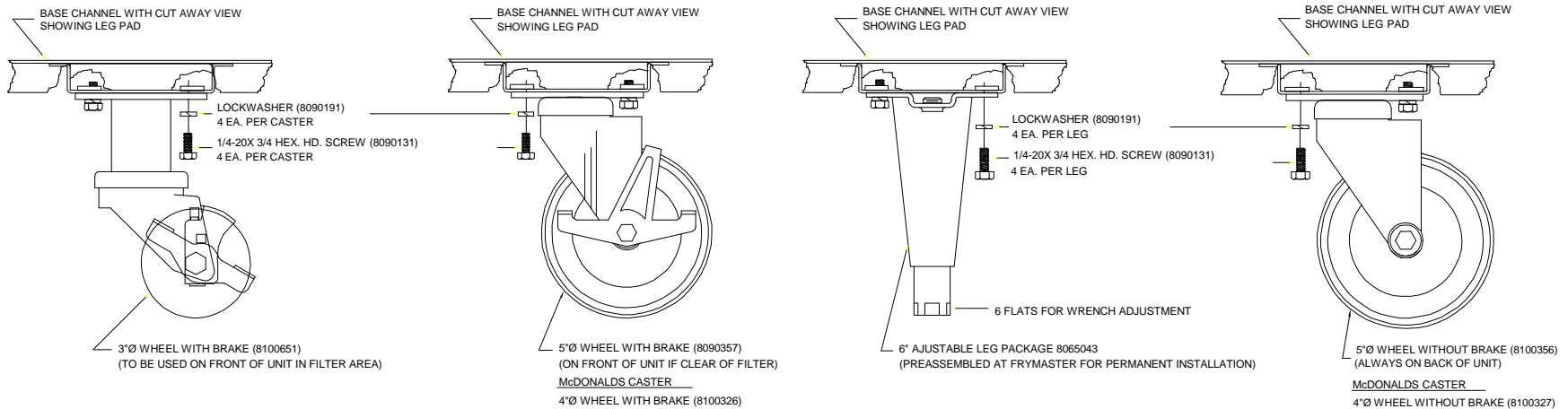

NOTE:

WHETHER INSTALLING CASTERS OR LEGS ALWAYS USE 4 EA. 1/4-20 X 3/4 HEX. HD. SCREWS (8090131) WITH 4 EA. LOCKWASHERS (8090191) FOR EACH CASTER OR LEG ASSEMBLY AND TORQUE EACH SCREW TO 50 INCH LBS. MINIMUM. SEE ABOVE DIAGRAMS FOR PROPER LOCATION OF LOCKWASHER.